

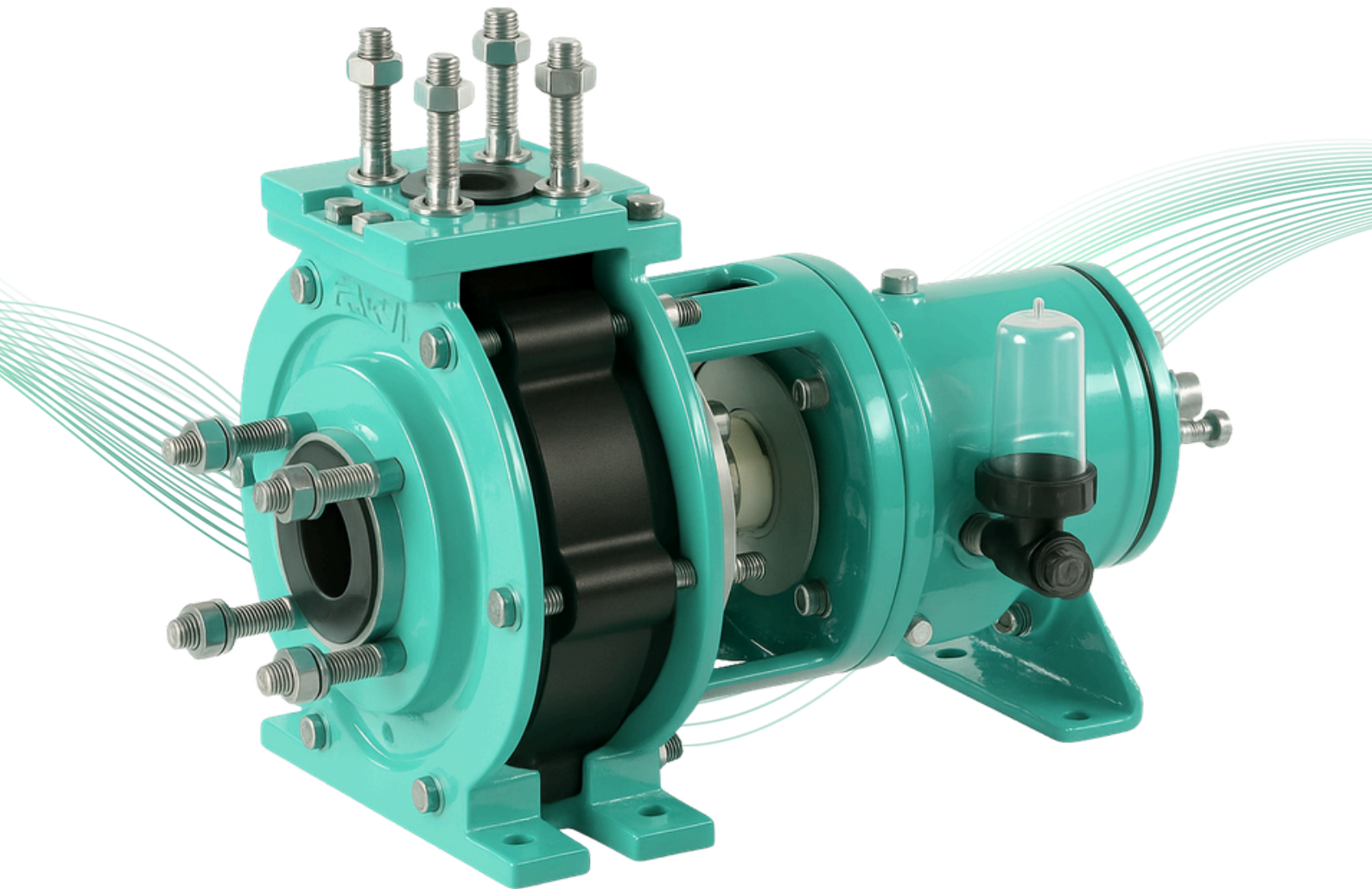

TranspumpServ
GLOBAL PVT LTD

CorroSafe (TcorroX)





Standard Chemical Process Pumps - Frame Type

PRODUCT SUMMARY:-

The CorroSafe pump series features a single-stage, end-suction centrifugal design with a horizontal, back pull-out configuration. The pumps have cast iron frames and injection-moulded wetted parts, allowing them to withstand high hydraulic pressures and flange loads, making them suitable for handling hazardous, corrosive, and toxic media. These pumps adhere to international standards, including ISO 2858, ISO 5199, and EN 22858, ensuring their design and dimensions meet industry requirements.

TECHNICAL DATA:-

Operating Frequency		50 Hz	60 Hz
Capacity [Q]	up to	210 m ³ /hr (925 US gpm)	1100 US gpm (250 m ³ /hr)
Head [H]	up to	100 m (328 ft)	400 ft (122 m)
Motor Power [P]	up to	55 kW (75 hp)	120 hp (90 kW)
Viscosity	up to	150 mPas (cP)	
Suction Lift	up to	8 m (26 ft) with priming chamber*	
Maximum Working Pressure		16 bar (232 psi)	
Maximum Specific Gravity [SG]		1.8 - 3	
Minimum Continuous Flow [MCF]		2.5 m ³ /hr (11 US gpm)	
Maximum Temperature		GFRPP: 90°C (194°F), PP-H: 82°C (180°F)	
Suction & Delivery Connection		ANSI B16.5 - Class 150, ISO 2084, DIN 2501, BS4504 - PN16*	
Shaft Seal		Single (TB/RA) & Double (DROTT) Mechanical Seals	
Bearings		Rolling Element Bearings	
Lubrication		Oil	
Motor Compatibility		IS 1231, IEC 72-1, NEMA*	

DESIGN FEATURES :-

The impeller features:-

- Optimized design: Hydrodynamically engineered for efficient performance
- Low NPSH requirement: Ensures smooth suction behaviour
- Reduced noise and vibration: Provides quieter operation
- Minimal axial loading: Reduces stress on bearings and seals, promoting longer lifespan

The lantern features:-

- Accurate alignment: Ensures proper positioning between the casing and bearing bracket
- Easy maintenance access: large openings on both sides, top, and bottom allow for:
- Simple seal unit maintenance
- Easy connection of auxiliary support units

Leak prevention:-

- O-ring seals and lip-type shaft seals prevent oil leakage and ensure a safe environment

The shaft features:-

- High stiffness: Low deflection ratio (<0.05 mm or 0.002 in) at seal faces, extending mechanical seal life
- Secure impeller locking: Positive locking mechanism prevents impeller failure due to incorrect rotation

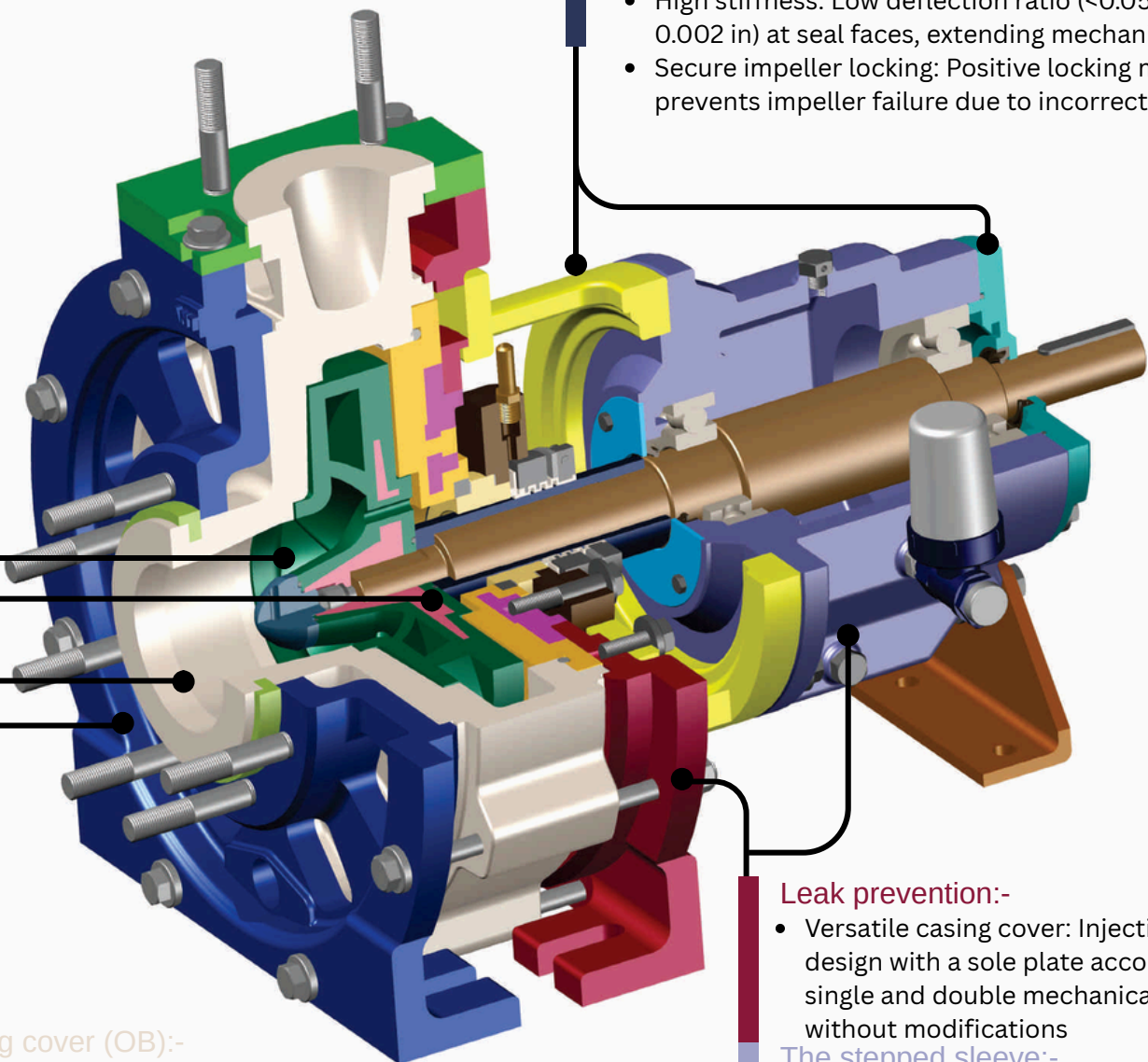

Bearing cover (OB):-

- Telescopic arrangement allows for adjusting impeller front clearance for optimal hydraulic performance
- High-load bearings: Designed to withstand high dynamic loads, exceeding standard lifetime expectations (17,500 hours)

Bearing Pedestal:-

- Rigid support: Heavy-duty bearing bracket and cover provide stability to the shaft and bearing assembly
- Effective cooling: Large oil sump capacity ensures efficient heat transfer, extending bearing life

Leak prevention:-

- Easy maintenance: Back pull-out design enables safe, simple, and quick assembly and disassembly of the pump

Leak prevention:-

- Versatile casing cover: Injection-molded design with a sole plate accommodates single and double mechanical seals without modifications

The stepped sleeve:-

- Ensures proper sealing: At the impeller rear side
- Aligns seal faces: Accurate alignment of rotary and stationary seal faces for optimal sealing performance

Volute Casing & Casing Frame:-

- Robust construction: Injection-molded, centerline discharge design handles high hydraulic pressures and flange loads
- Efficient fluid handling: Collects process media from the impeller and delivers it to the discharge connection
- Durable wetted parts: High wall thickness (≥ 10 mm) of non-metallic materials ensures extended pump life in corrosive applications

Mechanical Seal Options:-

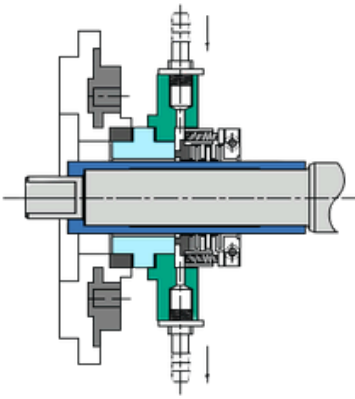

Single PTFE Bellows seal
(TB)

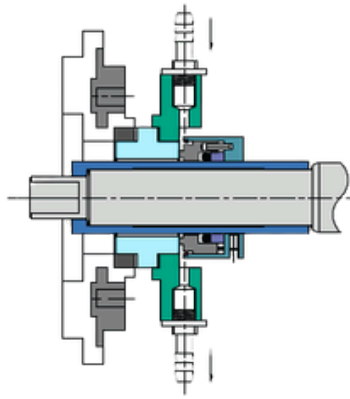

Single Pusher Seal
(RA)

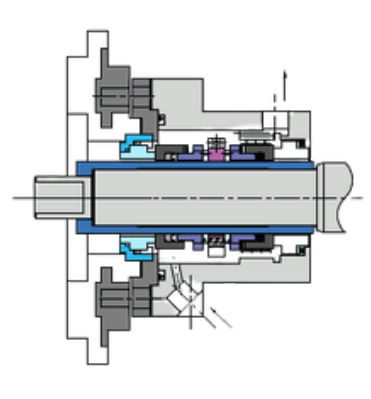

Double Pusher Seal
(DROTT)

The seal types offer varying levels of chemical resistance and application suitability:

- **Type TB:** Single, outside-mounted seal with PTFE bellows, providing universal chemical resistance for clean and corrosive media.
- **Type RA:** Single, outside-mounted seal with fluoroelastomer (FKM/FFKM), designed for highly corrosive and homogeneous slurries.
- **Type DROTT:** Double, back-to-back seal with fluoroelastomer (FKM/FFKM) and fluoropolymer (PTFE), suitable for hazardous chemicals, crystallizing media, and volatile liquids, requiring a pressurized buffer liquid system.

OPERATING PARAMETERS :-

Type		TB	RA	DROTT
Pressure	upto	5 bar (75 psi)	27.6 bar (400 psi)	27.6 bar (400 psi)
Temperature	upto	71°C (160°F)	204°C (400°F)	204°C (400°F)
Shaft Speed	upto	10 m/s (33 fps)	23 m/s (75 fps)	23 m/s (75 fps)

*Values for Flowserve seals. Other seals available on request.

THE TESTING FACILITIES INCLUDE:

- Pump testing: Temperature, noise, and vibration measurements to evaluate performance.
- Impeller testing: Dynamic balancing to ensure smooth operation.
- Shaft testing: Ultrasonic testing for defect detection.
- Cast parts testing: Chemical analysis, mechanical testing, spectrometry, and dye penetrant testing for quality assurance.
- Wetted parts testing: Spark testing and hydrostatic testing for integrity verification.
- Hydraulic performance testing: Testing according to IS 5120 standards on a 15,000-liter test bench with calibrated instruments, including magnetic flow meters, control valves, pressure gauges, and motors (1-100 HP, 1440 & 2900 rpm).

Hydraulic Performance:-

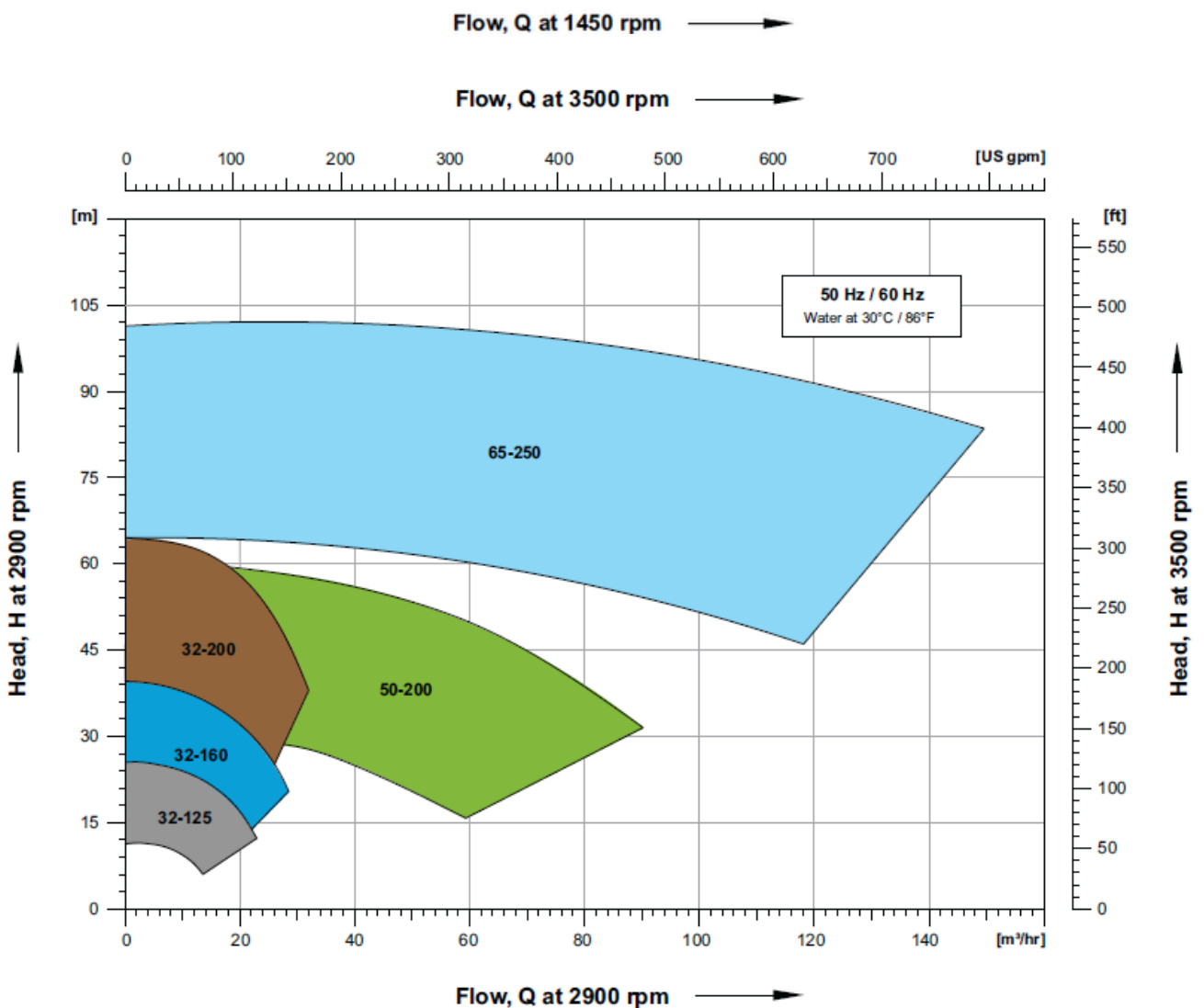
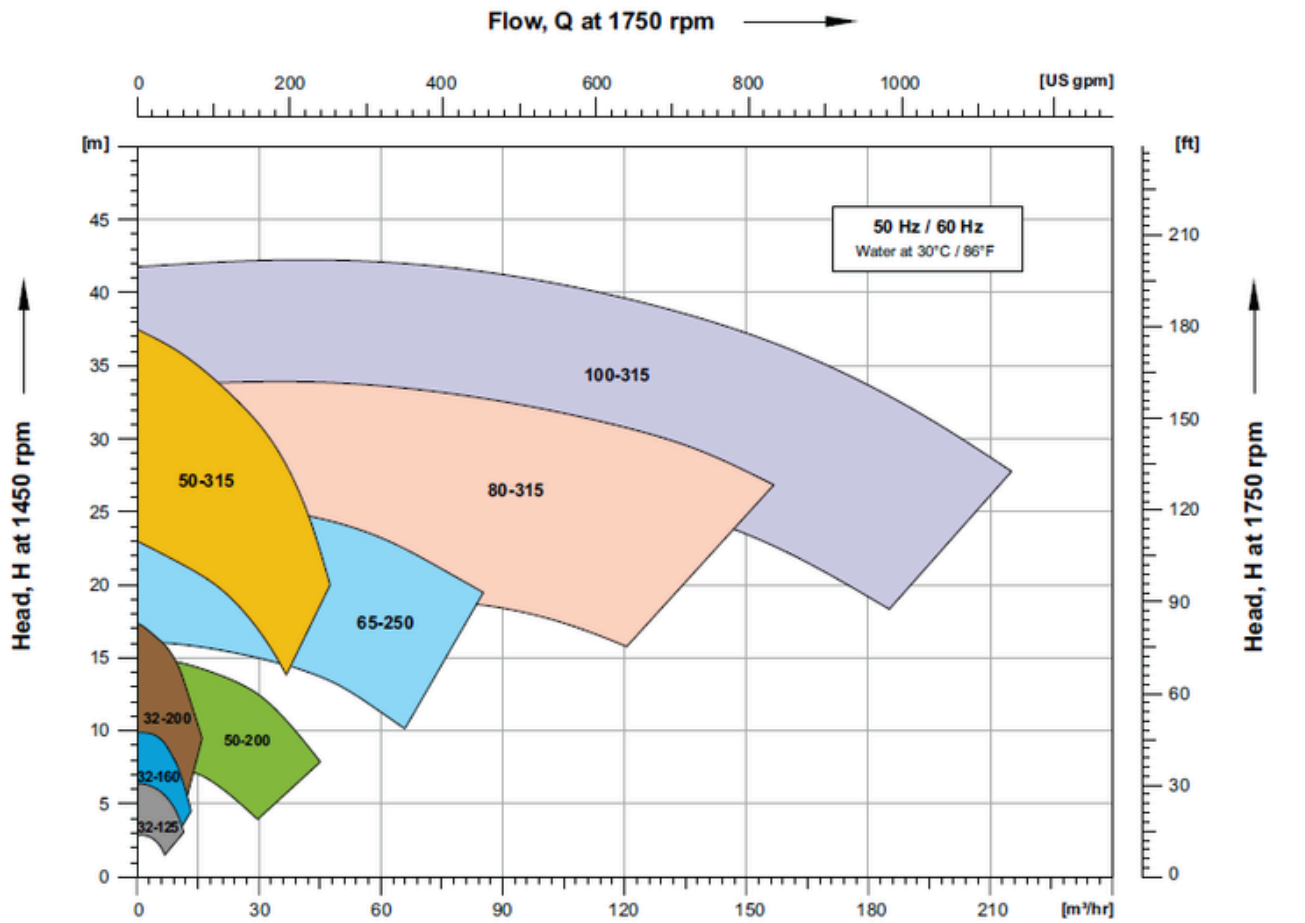

Corro Safe (TCORROX)

PUMP IDENTIFICATION:-

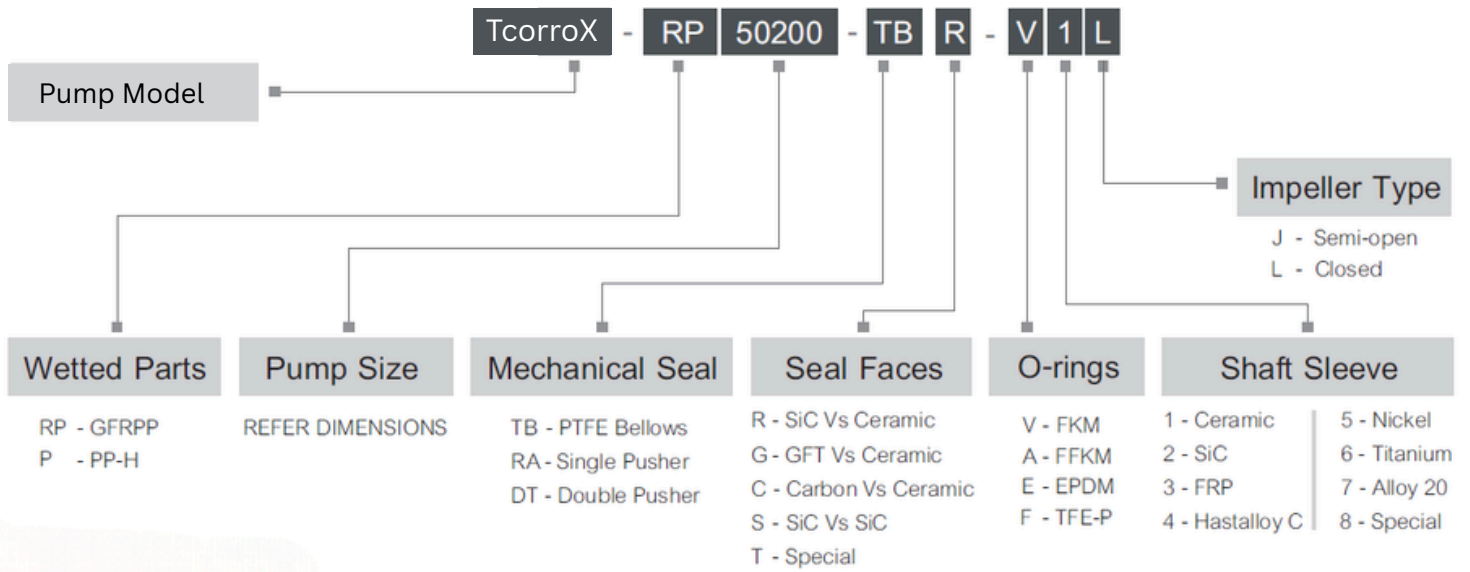

PUMP DIMENSION:-

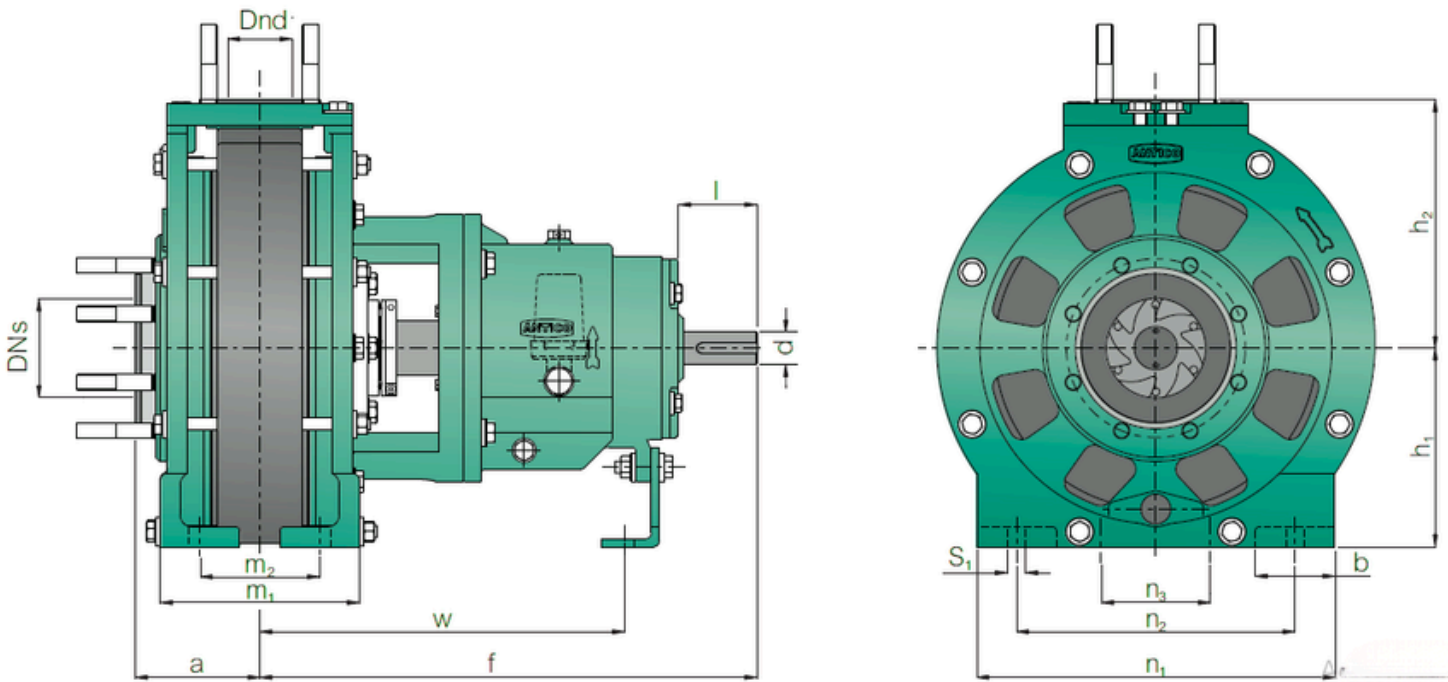

MODELS	PUMP DIMENSIONS															
	DNs	DNd	a	f	h ₁	h ₂	b	m ₁	m ₂	n ₁	n ₂	n ₃	w	S ₁	d	l
50- 32-125	50	32	80	385	112	140	50	100	70	190	140	110	285	M12	24	50
50- 32-160	50	32	80	385	132	160	50	100	70	240	190	110	285	M12	24	50
50- 32-200	50	32	80	385	160	180	50	100	70	240	190	110	285	M12	24	50
80- 50-200	80	50	100	385	160	200	50	100	70	265	212	110	285	M12	24	50
80- 50-315	80	50	125	500	225	280	65	125	95	345	280	110	370	M12	32	80
100- 65-250	100	65	125	500	200	250	80	160	120	360	280	110	370	M16	32	80
125- 80-315	125	80	125	530	250	315	80	160	120	400	315	110	370	M16	42	110
125-100-315	125	100	140	530	250	315	80	160	120	400	315	110	370	M16	42	110

All Dimensions in mm

APPLICATION:-

The TcoroX Series pumps are engineered for handling corrosive liquids, with or without contaminants, in industries such as:

1. CHEMICAL PROCESSING:

- Acidic effluent handling in chemical plants
- Fume extraction systems for corrosive vapors
- Transfer of aggressive chemicals in petrochemical and specialty chemical industries

2. METAL FINISHING:-

- Plating solution handling in electroplating, anodizing, and surface treatment processes
- Transfer of corrosive chemicals used in metal cleaning, pickling, and passivation

3. CHLOR-ALKALI INDUSTRY:-

- Acid handling (e.g., hydrochloric acid, sulfuric acid)
- Alkali handling (e.g., sodium hydroxide, potassium hydroxide)
- Transfer of chlorine gas, caustic solutions, and other corrosive chemicals used in water treatment, pulp and paper, and chemical synthesis

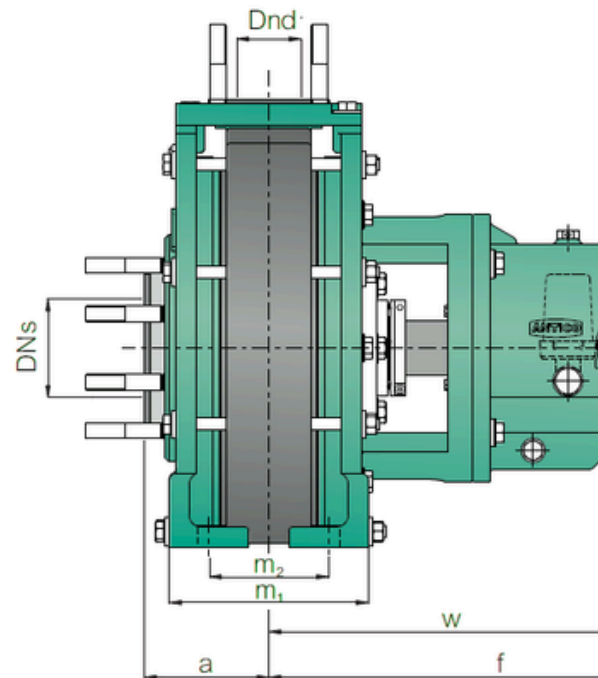

These pumps are suitable for applications where reliability and durability are critical in harsh chemical environments. They can be used in various sectors, including:

- Chemical manufacturing
- Pharmaceuticals
- Water treatment
- Pulp and paper
- Electroplating and surface treatment
- Petrochemicals

THE TCOROX SERIES PUMPS ARE DESIGNED TO WITHSTAND THE CORROSIVE EFFECTS OF AGGRESSIVE LIQUIDS, ENSURING LONG-TERM PERFORMANCE AND MINIMIZING DOWNTIME IN DEMANDING INDUSTRIAL APPLICATIONS.



TranspumpServ

GLOBAL PVT LTD

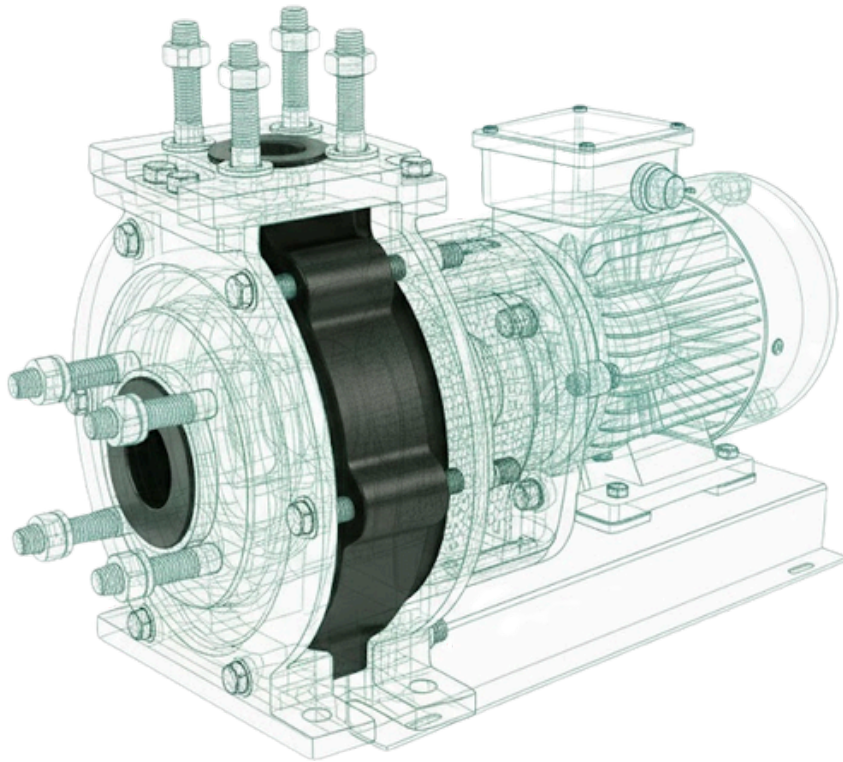

India

Transpumpserv Global (HQ)

📍 Vadodara – Gujarat, INDIA

**Transpumpserv Engineering
(Mfg. Unit-1)**

Valod – Surat, INDIA

☎ + 91 92136 11384



Canada

Transpumpserv Alberta Inc.

📍 Manulife Place,
3400 – 10180 101 St NW
Edmonton, Alberta T5J 3S4
Canada

☎ +1 (789) 695-3233

Follow Us :   

✉ info@transpumpservglobal.com

🌐 www.transpumpservglobal.com