

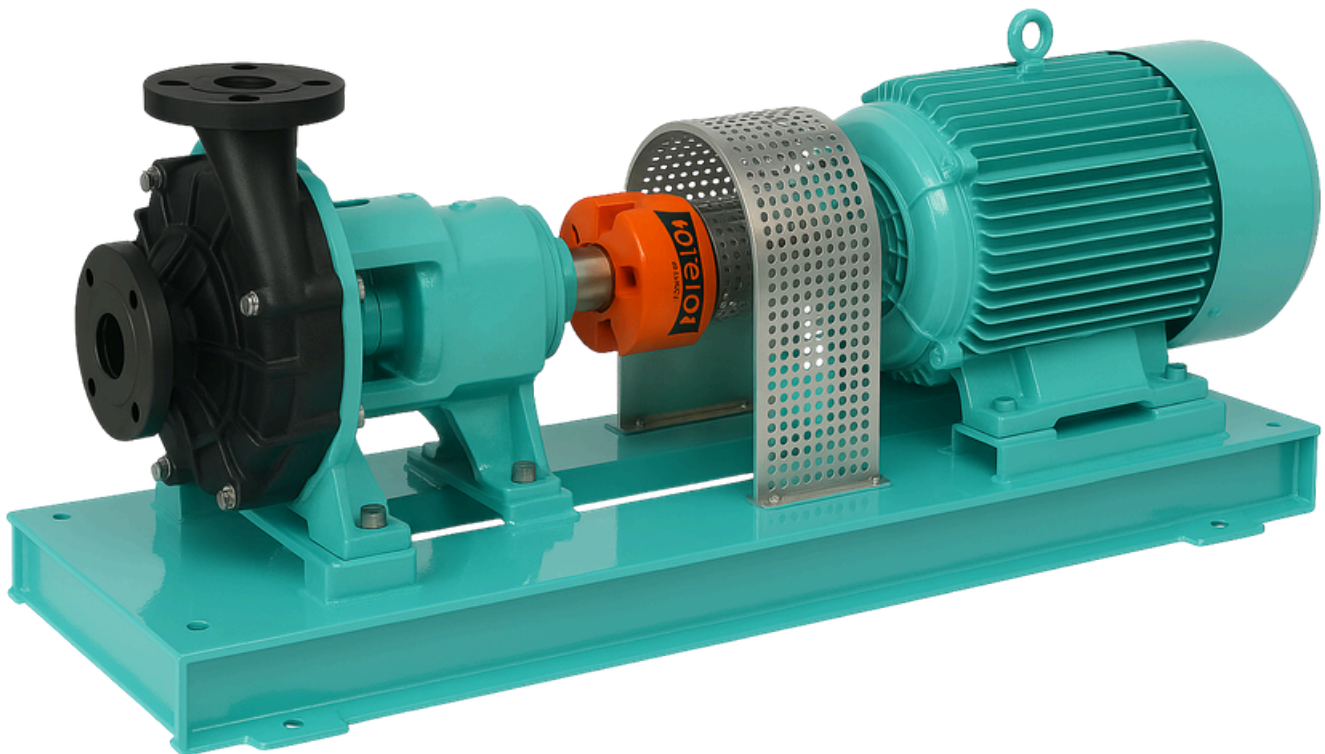

TranspumpServ  
GLOBAL PVT LTD

# CorroSafe (TcorroY)



**Non Metallic Mechanical Seal Pumps**

**PP-H, PVDF, ETFE**

# Design Features

- **Casing Cover Design**
- **Sleeve Functionality**
- **Sleeve Functionality**
- **Shaft & Key**
- **High-Performance Bearings**
- **Sturdy Shaft Design**
- **Efficient Impeller Performance**
- **Bearing Pedestal**

A proprietary positive locking system prevents failure from incorrect rotation and ensures maximum torque transmission.

The casing cover features a polymer-lined cast construction, accommodating both single and double mechanical seals without requiring modifications.

The stepped sleeve ensures precise alignment of the rotary and stationary seal faces, while also facilitating effective sealing at the impeller's rear side.

Our pump's bearings are engineered to withstand high dynamic loads, exceeding standard lifetime expectations with a lifespan of over 17,500 hours. This robust design ensures reliable operation and minimizes downtime.

Our volute casing boasts a unique design, crafted from non-metallic materials with substantial wall thickness. This construction ensures a smooth flow of pumping media, efficient operation, and exceptional resistance to both internal and external corrosion.

Our pump's impeller is expertly designed with hydrodynamic optimization, featuring a closed or semi-open radial configuration. This design ensures optimal suction performance, low NPSH requirements, reduced noise and vibration, and minimized axial loading on bearings and seals, resulting in smooth and efficient operation.

Our pump features a single-piece bearing bracket, lantern, and leg design, providing a sturdy foundation for simple assembly and accurate installation. This integrated structure ensures reliable performance and reduces maintenance complexity.

Our pump's bearings are engineered to withstand high dynamic loads, exceeding standard lifetime expectations with a lifespan of over 17,500 hours. This robust design ensures reliable operation and minimizes downtime.

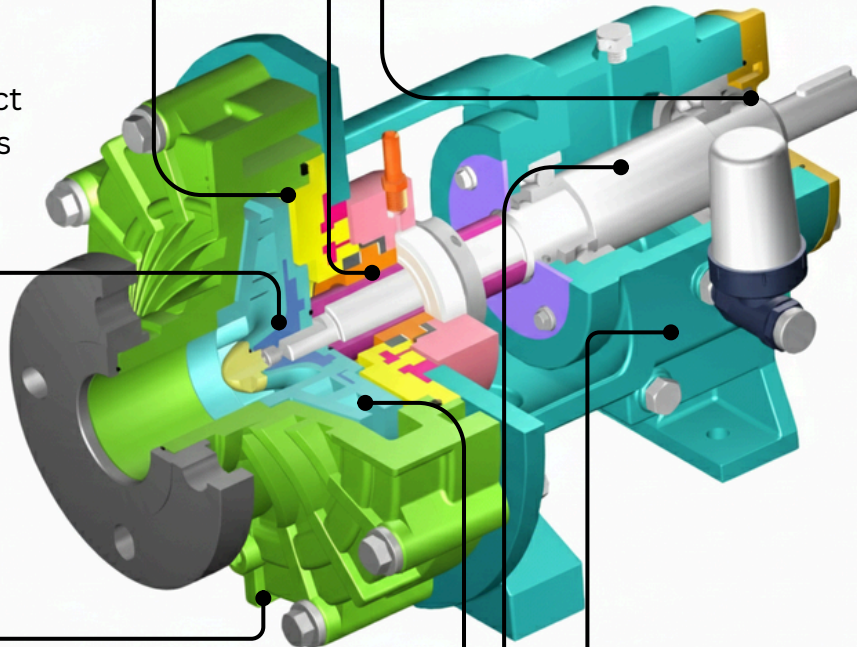

# MECHANICAL SEAL OPTIONS

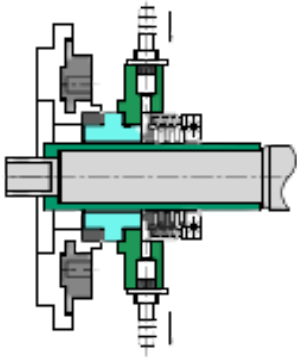

Single PTFE Bellows seal (TB)

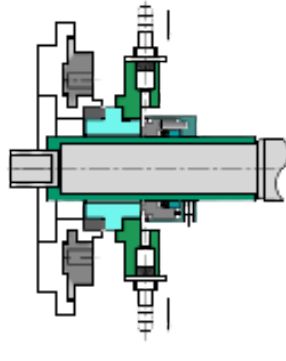

Single Pusher Seal (RA)

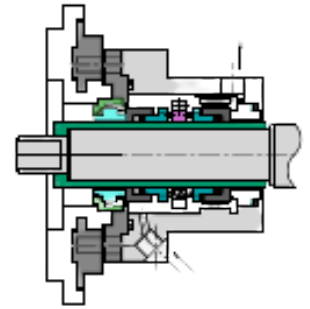

Double Pusher Seal (DROTT)

## Our pumps offer three seal types:-

- 1. Type TB:** Single, outside-mounted seal with PTFE bellows, providing universal chemical resistance for clean and corrosive media.
- 2. Type RA:** Single, outside-mounted seal with fluoroelastomer, designed for highly corrosive and homogenous slurries.
- 3. Type DROTT:** Double, back-to-back seal with fluoroelastomer and fluoropolymer, suitable for hazardous chemicals, crystallizing media, and volatile liquids, requiring a pressurized buffer liquid system.

## Flexible Lubrication Options:-

### Our pump offers two lubrication options:

- 1. Grease Lubrication:** Suitable for applications up to 120°C/250°F, with grease nipples for easy maintenance. Greased-for-life/sealed-for-life bearings are also available.
- 2. Oil Lubrication:** Ideal for high-temperature applications up to 180°C/355°F, featuring a constant level oiler and a large oil sump (430 ml) for effective heat transfer and cooler bearings.

## Robust Bearing Bracket Design:-

- **Integrated Bearing Bracket:** A single-piece design combining the bearing bracket, lantern, and leg provides a robust foundation, reducing downtime and maintenance complexity.
- **Durable Design:** Our monolithic bearing bracket ensures precise alignment, minimizes coupling misalignment, and enhances overall pump reliability and maintainability.

## Robust Shaft Design:-

The CorroSafe Series pump features a shaft designed with solid and sleeved options, prioritizing a low shaft stiffness ratio ( $L^3/D$ ) to minimize deflection. This design enhances seal and bearing life by reducing vibration and stress. The shaft is engineered to accommodate standard single and double mechanical seals, meeting First Obstruction Length (FOB) requirements for seamless integration.

Type		TB	RA	DROTT
Pressure	up to	5 bar (75 psi)	27.6 bar (400 psi)	27.6 bar (400 psi)
Temperature	up to	71°C (160°F)	204°C (400°F)	204°C (400°F)
Shaft Speed	up to	10 m/s (33 fps)	23 m/s (75 fps)	23 m/s (75 fps)

# PRODUCT SUMMARY

The **CorroSafe Series pumps** are non-metallic, single-stage centrifugal pumps designed for chemical applications. They feature an injection-moulded construction, horizontal design, side discharge, and back pull-out capability for easy maintenance. **These pumps provide cost-effective solutions with reduced life cycle costs, making them ideal for various chemical processing needs.**

## Technical Data :-

Operating Frequency		50 Hz	60 Hz
Capacity [Q]	up to	40 m <sup>3</sup> /hr (176 US gpm)	220 US gpm (50 m <sup>3</sup> /hr)
Head [H]	up to	38 m (125 ft)	176 ft (54 m)
Motor Power [P]	up to	15 kW (20 hp)	25 hp (18.5 kW)
Viscosity	up to	150 mPas (cP)	
Suction Lift	up to	8 m (26 ft) with priming chamber*	
Maximum Working Pressure		10 bar (145 psi)	
Maximum Specific Gravity [SG]		1.8 - 3	
Minimum Continuous Flow [MCF]		2.5 m <sup>3</sup> /hr (11 US gpm)	
Maximum Temperature		PP-H: 82°C (180°F), GFRPP: 90°C (194°F), PVDF: 104°C (220°F), ETFE: 121°C (250°F)	
Suction & Delivery Connection		ANSI B16.5 - Class 150, DIN 2501, BS4504 - PN16, BSP or NPT*	
Shaft Seal		Single (TB/RA) & Double (DROTT) Mechanical Seals	
Bearings		Rolling Element Bearings	
Lubrication		Grease / Oil	
Motor Compatibility		IS 1231, IEC 72-1, NEMA*	

## Material:-

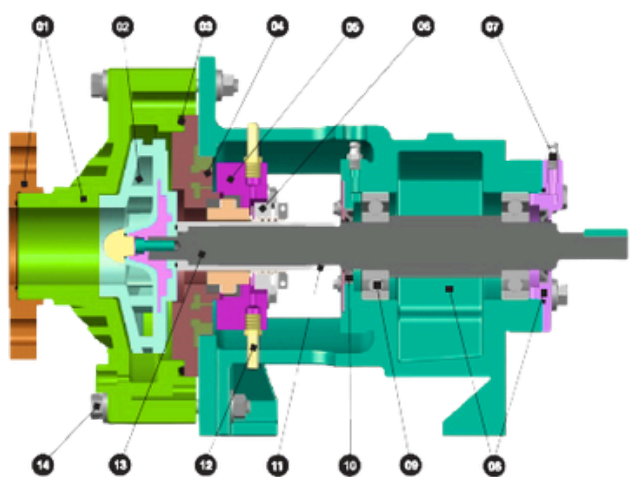

Casing & Flanges 01	PP-H <sup>1</sup> / GFRPP <sup>2</sup> / PVDF <sup>3</sup> / ETFE <sup>4</sup>
Impeller 02	PP-H / GFRPP / PVDF / ETFE
O-Rings 03	FKM / FFKM / EPDM / TFE-P
Casing Cover 04	PP-H / GFRPP / PVDF / ETFE
Gland Plate 05	GFRPP / PVDF / Stainless Steel
Mechanical Seal (Stationary & Rotary) 06	Ceramic / SiC <sup>5</sup> / GFT <sup>6</sup> / Carbon
Grease Nipple 07	Stainless Steel
Bearing Bracket & Cover 08	Cast Iron*
Rolling Element Bearings 09	Carbon Chromium Steel
Oil Seals 10	Chlorobutadiene Rubber
Sleeve 11	Ceramic / SiC / FRB <sup>7</sup> / Super Alloys
Male Hose Barb Nipple 12	Brass
Shaft 13	EN Steel / SS316 / Super Alloys
Fasteners 14	Stainless Steel



**GFRPP** : Suitable for Aggressive Media up to 90°C (194°F)



**CFRPVDF** : Suitable for Corrosive, Hazardous Media up to 110°C (230°F)



**PP** : Available on Request

# Hydraulic Performance

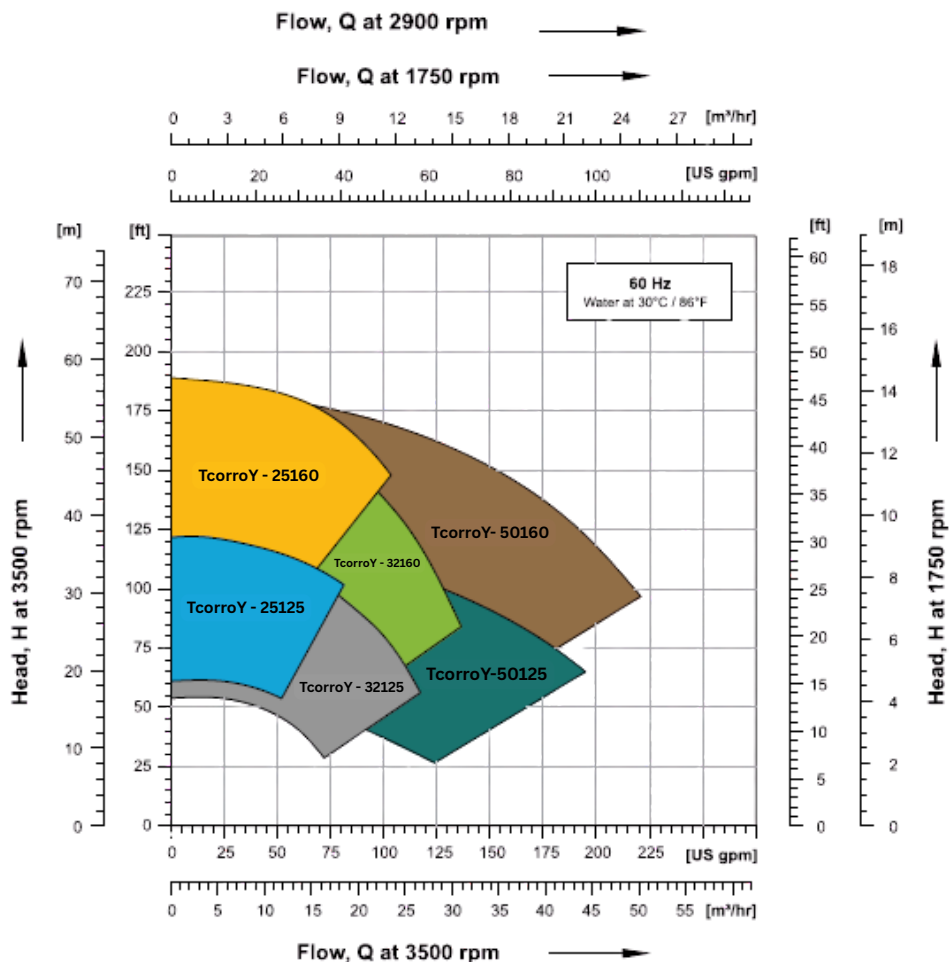
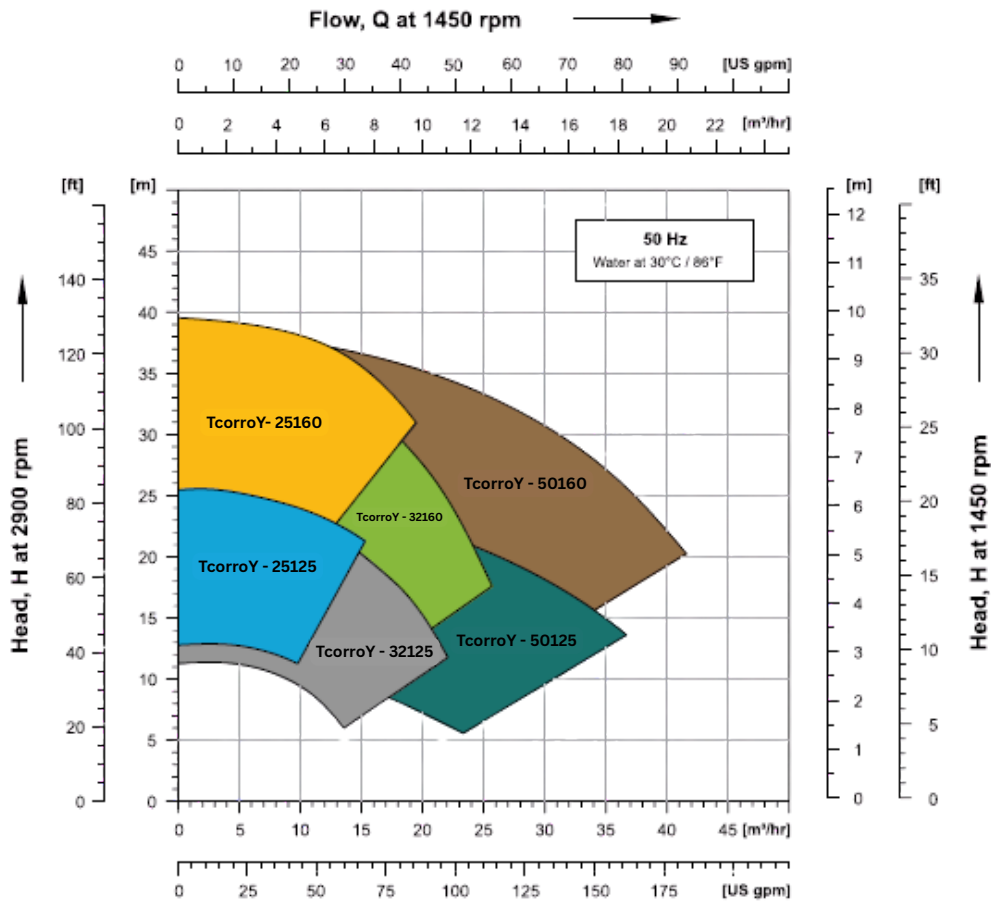

# PUMP IDENTIFICATION

## • CorroSafe Series (TcorroY)

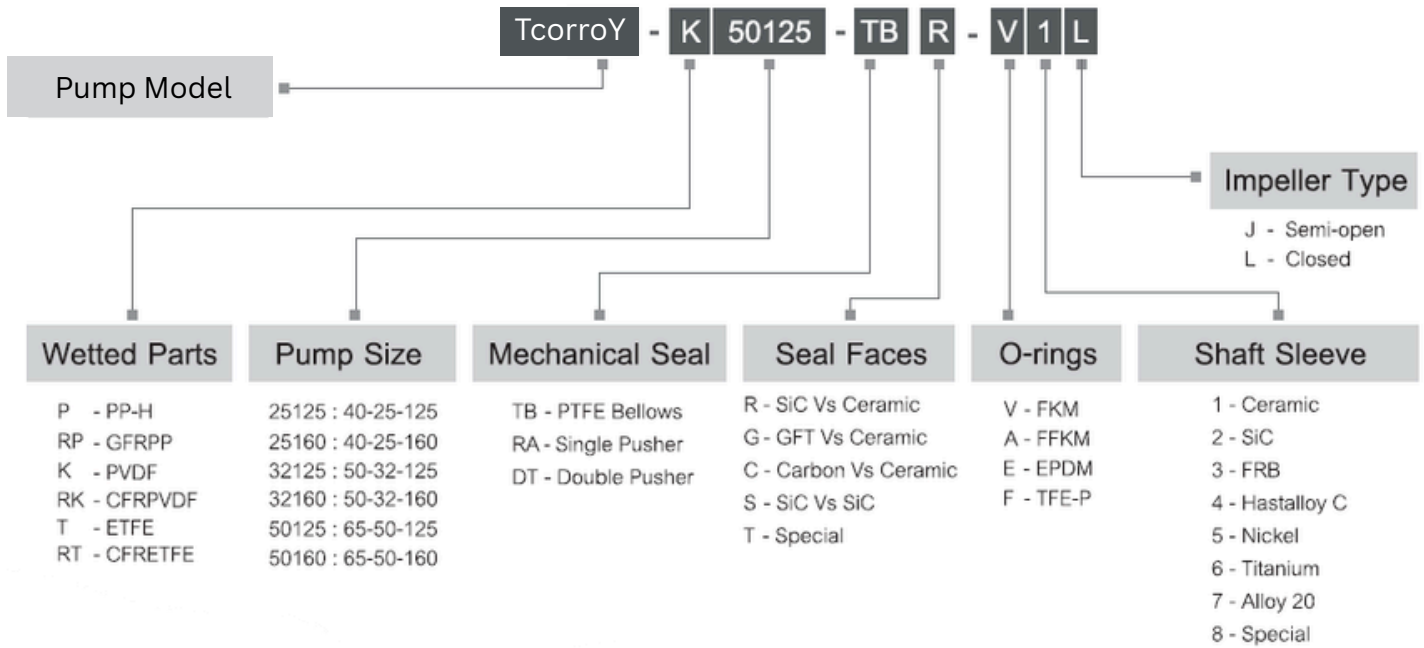

## PUMP DIMENSION :-

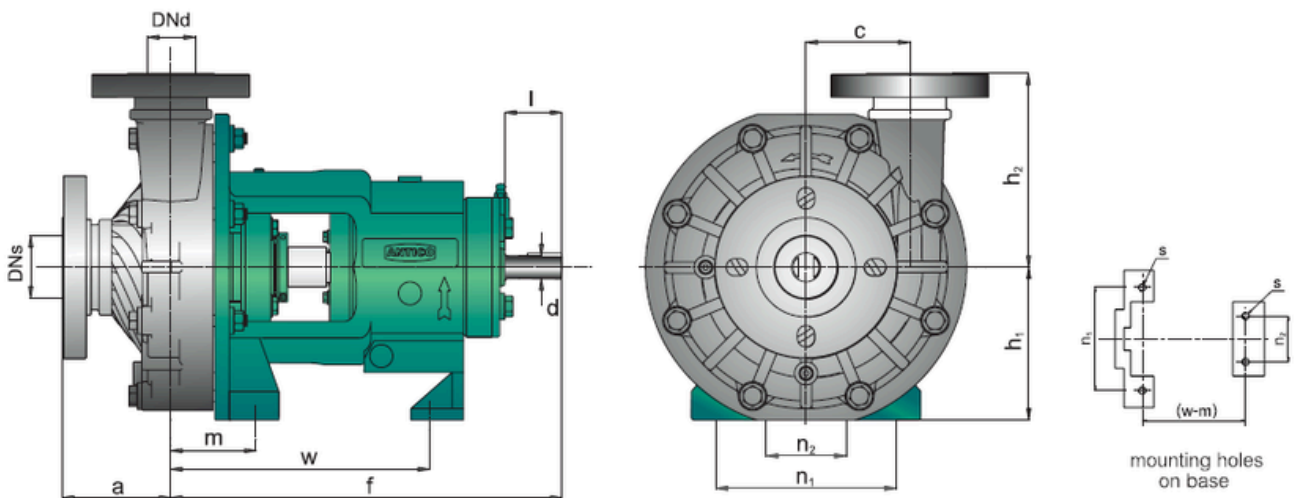

MODELS	PUMP DIMENSIONS													
	DNs	DNd	a	f	c	h <sub>1</sub>	h <sub>2</sub>	m	n <sub>1</sub>	n <sub>2</sub>	w	s	d	l
TY - 25125	40	25	100	410	90	160	182	95	180	80	275	M12	24	60
TY - 25160	40	25	110	410	104	160	208	95	180	80	275	M12	24	60
TY - 32125	50	32	100	410	90	160	182	95	180	80	275	M12	24	60
TY - 32160	50	32	110	410	104	160	208	95	180	80	275	M12	24	60
TY - 50125	65	50	100	410	96	160	182	95	180	80	275	M12	24	60
TY - 50160	65	50	110	410	108	160	208	95	180	80	275	M12	24	60

All Dimensions in mm



**TranspumpServ**  
GLOBAL PVT LTD

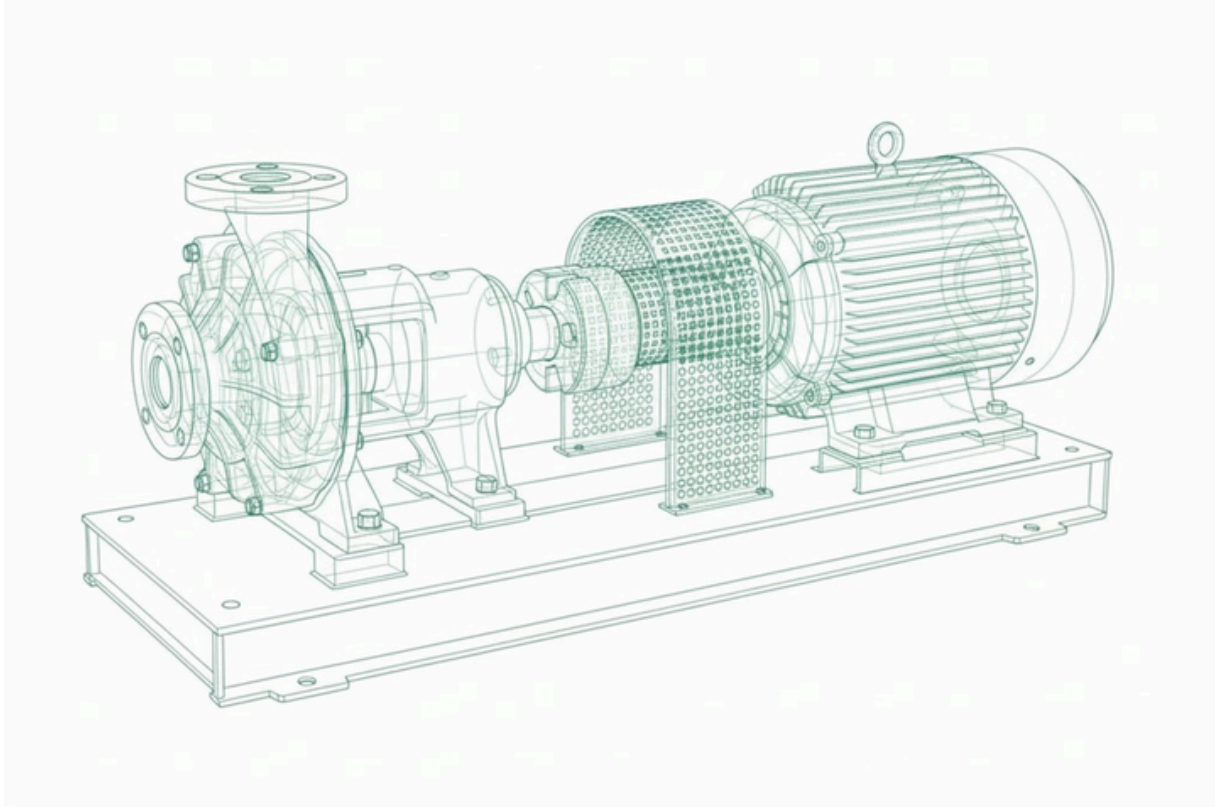

## India

**Transpumpserv Global (HQ)**

📍 Vadodara – Gujarat, INDIA

**Transpumpserv Engineering  
(Mfg. Unit-1)**

Valod – Surat, INDIA

☎ + 91 92136 11384



## Canada

**Transpumpserv Alberta Inc.**

📍 Manulife Place,  
3400 – 10180 101 St NW  
Edmonton, Alberta T5J 3S4  
Canada

☎ +1 (780) 695-3232

Follow Us :   

✉ [info@transpumpservglobal.com](mailto:info@transpumpservglobal.com)  [www.transpumpservglobal.com](http://www.transpumpservglobal.com)